



INSTALLATION AND MAINTENANCE MANUAL

AUSTART ATS93 TURBINE STARTER



K.H. EQUIPMENT PTY. LTD.

14-16 WESTPOOL DRIVE, HALLAM, VICTORIA, 3803, AUSTRALIA
PH: +61 3 8786 4766 FX: +61 3 9796 4878
info@khequipment.com.au www.khequipment.com.au

NOTICE

THIS MANUAL CONTAINS IMPORTANT SAFETY INFORMATION. IT IS IMPORTANT THAT THE ENTIRE CONTENTS BE STUDIED BEFORE INSTALLATION AND OPERATION. IT ONLY REFLECTS GENERIC INFORMATION RELATING TO A STANDARD AUSTART ATS93 TURBINE STARTER. VARIOUS OTHER OPTIONS ARE AVAILABLE TO PROVIDE INERTIA DRIVE SYSTEMS, HARSH ENVIRONMENT MUFFLERS OR THEADED EXHAUSTS TO MEET SPECIFIC APPLICATION REQUIREMENTS.

FOREWORD

This manual contains instructions for the installation, maintenance and operation of your new ATS93 AUSTART Air Starter Motor. It has been designed to provide you with safe and reliable service. However, it is both a pressure vessel and a piece of rotating machinery. Therefore operators and maintenance personnel must exercise good judgement and appropriate safety practices to avoid damage to the equipment and prevent personal injury. The instructions in this manual are intended for personnel with a general training in the operation and maintenance of air starter equipment. It should be understood that the information contained in this manual does not relieve the operating and maintenance personnel of the responsibility for exercising good normal judgement in the operation and care of air starter equipment and their associated systems.

Throughout this manual you will encounter the words: 'WARNING', 'CAUTION' and 'NOTICE'. These paragraphs are intended to emphasise certain areas where personnel safety and satisfactory starter operation may be compromised should the message be ignored. The definitions of these words are as follows:-



An operating procedure, practice, etc. that if not strictly observed could result in personal injury.

CAUTION

An operating procedure, condition, etc. that if not followed, could result in damage to, or the destruction of equipment.

NOTICE

An operating procedure, condition, etc. that is essential to highlight and observe.

It is advisable that a safety program be established to address the safety issues detailed within this manual before installing, operating or maintaining this equipment. It is important such a program covers the hazards associated with compressed air.



Do not install this starter other than in accordance with the instructions detailed in this manual.

These instructions should be read completely before beginning installation and should be available to personnel responsible for operating and maintaining this equipment. The unit is capable of trouble free operation when properly applied, installed and maintained.

Extra copies of this manual are available from your local AUSTART Air Starter distributor or the factory.

This manual is designed to cover all situations normally experienced when installing, operating and maintaining this equipment. In the event situations are encountered that are not covered by this manual, consult your AUSTART agent or K.H. Equipment Pty Ltd direct.

AUSTART PRODUCT NUMBERING



MODEL PREFIX CODES:
AS AUSTART VANE STARTER
ATS AUSTART TURBINE STARTER

	STARTER MODEL	FLANGE CODE	PINION CODE	SPECIAL FEATURES
AS50	Austart Air Starter	01 SAE 1	09 9TH 3MOD R	B BCB (Beryllium Copper Bronze Pinion)
ATS53	Austart Turbine Starter	02 SAE 2	10 10TH 8/10 R	E Threaded Exhaust 1.5"
ATS54	(ATS53 OH) Austart Turbine Starter	03 SAE 3	11 11TH 6/8 R	F Threaded Exhaust 2" Bolt On
AS55	(AS50 OH) Austart Air Starter	04 SAE 4	12 12TH 8/10 R	G Threaded Exhaust 2"
AS61	Austart Air Starter	Other options available	13 12TH 8/10 L	H Highway Special
ATS63	Austart Turbine Starter		14 11TH 6/8 L	I Inertia Drive
ATS64	(ATS63 OH) Austart Turbine Starter		15 10TH 8/10 L	J Threaded Exhaust Elbow 2"
AS66	Austart Air Starter		16 9TH 3MOD L	K Kelly Spinner Muffler
AS67	Austart Air Starter		Other options available	M Mining Spec. (Cast Iron)
AS68	(AS6070) Austart Air Starter			N Short Nose (Inertia ATS77)
AS69	(AS67OH) Austart Air Starter			P Motor Ports 90°
AS70	Austart Air Starter			R Reduced Muffler
ATS71	Austart Turbine Starter			S Short Muffler
ATS73	Austart Turbine Starter			T Threaded Exhaust 3"
ATS77	Austart Turbine Starter			U U Configuration
AS75	(AS70 OH) Austart Air Starter			V Value Muffler (ATS77)
AS78	(AS7080) Austart Air Starter			X Special – Refer Factory
AS80	Austart Air Starter			
ATS83	Austart Turbine Starter			
ATS84	(ATS83 OH) Austart Turbine Starter			
AS85	(AS80 OH) Austart Air Starter			
AS90	Austart Air Starter			
ATS93	Austart Turbine Starter			
ATS94	(ATS93 OH) Austart Turbine Starter			
AS95	(AS90 OH) Austart Air Starter			
AS100	Austart Air Starter			
ATS103	Austart Turbine Starter			
ATS183	Austart Turbine Starter			

EXAMPLES OF BASIC STARTER PRODUCT NUMBERING

ATS63-0110M	PERKINS 1006	SAE1	10TH	MINING SPEC
ATS63-0409M	MWM D916-6	SAE4	9TH	MINING SPEC
ATS73-0311	CUMMINS N14	SAE3	11TH	
ATS73-0314	CUMMINS N14	SAE3	11TH	LH
ATS73-0311I	DETROIT 12V71	SAE3	11TH	INERTIA DRIVE
ATS73-0314I	DETROIT 12V71	SAE3	11TH	INERTIA DRIVE LH
ATS73-0312M	CATERPILLAR 3306	SAE3	12TH	MINING SPEC
ATS83-0311IT	WAUKESHA 7072	SAE3	11TH	INERTIA THREADED EXHAUST

INSTALLATION AND PREPARATION FOR OPERATION



- Maximum pressure for AUSTART starting equipment is 150psi (standard operating pressure is 100psi).
- Ensure air supply is isolated before installation, removal, maintenance or adjustment of your AUSTART starter.
- Before any starter is taken out of service first bleed the air receiver of air and any moisture that may have accumulated by opening up the drain valve. Do not bleed by removing the receiver plugs.
- Remove air hoses to ensure complete safety once the air supply has been isolated and the receiver has been bled.
- The air receiver must be manufactured to an applicable pressure vessel code such as AS1210 or similar.
- Only use air hoses and fittings that are of adequate size as indicated in the installation schematic (page 6).
- Always carry out a pressure test on the complete starting system according to Clause 8 on Page 5 before beginning operation. Do not begin operations until satisfied the unit has been installed correctly.
- Do not initiate a start until all components have stopped rotating, this includes the engine and starter motor.
- Always use recommended lubricants where prescribed by this manual. Under no circumstances use flammable or volatile liquids.
- Ensure all fasteners are torqued to the values prescribed in this manual. Use thread sealant where indicated.
- To ensure warranty provisions are not invalidated use only genuine AUSTART replacement parts. Non-genuine parts may cause service and performance problems and may affect the safe operation of your starter.

PRELIMINARY INSTALLATION REQUIREMENTS

Numbers in brackets refer to items numbers on Exploded View drawing on page 8.

1. Your AUSTART Starter is flange mounted. Before installing the starter carefully study the mating position of the AUSTART starter and engine flanges to determine whether the air inlet port orientation or nose housing (45) geometry will suit your particular installation. If not suitable re-orientate as follows -
 - Carefully remove the band clamp (31), but do not remove. The two housings can now be rotated relating to each other without separation.
 - Re-orientate the housings to the desired position and torque the band clamp (31) to 4ft lb (6Nm).
2. Ensure pinion is suitable for engine application ie. correct pitch, diameter and number of teeth.
3. Check flange to ring gear (FRG) spacing is correct and that flange spacers are not required. Pinion should be FRG less 1/8" (3mm) when at rest.
4. Check AUSTART starter clears all obstacles and the flange mounts to flywheel housing squarely without using undue force.
5. Ensure the hoses, fittings and starter ports are clean and free from dirt and foreign objects. Ensure they remain so during installation.
6. For optimum AUSTART starter performance, ensure air supply pipes or hoses have an internal diameter of at least 1-1/4" (32mm) refer Installation Schematic on page 6. In the event line, length must be longer than 15ft (5m) a size of 1-1/2" (40mm) should be used. Keep the number of fittings and the length of piping to a minimum. Avoid the use of reducing bushes and other fittings that could impede air flow.

INSTALLING THE STARTER AND PIPEWORK

Refer to the Starter Installation Schematic drawing on page 6.

1. The air supply line should ideally exit from the top or side of the air receiver.

CAUTION

Do not connect air supply line to the bottom of the air receiver. Moisture and system contaminants collect at the receiver bottom and can damage the AUSTART starter internals if allowed to pass through. Periodically drain moisture from the air receiver using a drain valve connected at the receiver bottom.

2. Install a 100 mesh 'Y' strainer. A 'Y' strainer installed before the relay valve will provide protection to the valve and AUSTART starter from contaminants that may have accumulated in the air receiver. Fitting of an inline 'Y' strainer (as described above) is also required to ensure the AUSTART starter is covered by our product warranty.

NOTICE

Ensure the inlet side of the 'Y' strainer faces the receiver ie. the direction arrow points away from the receiver.

3. Connect the RV1500M relay valve and the 'Y' strainer using a 1-1/2" short nipple.

NOTICE

Ensure the inlet side of the relay valve connects to the exit side of the 'Y' strainer.

4. Mount the starter control button SC25 onto the vehicle dash-board or appropriate control panel and connect to the air receiver using a minimum of 1/4" (6mm) line.

NOTICE

Ensure the inlet side of the starter control button connects to the line from the receiver. Any safety 'switches' should be installed in this line between the starter control button and the air receiver.

5. Determine the practicality of running the 1-1/4" -1-1/2" air supply hose or pipe from the exit of the relay valve to the inlet of the AUSTART starter after the AUSTART starter is mounted. It may be easier to fit the hose before the AUSTART starter is mounted in position.
6. Once the AUSTART starter is mounted, fit the remaining 1/4" (6mm) control lines from the AUSTART starter to the starter control button and relay valve respectively (refer page 6).
7. Make all hose or pipe connections leak proof using a suitable thread sealant.
8. Once the connections have been made, pressurise the system and check for leaks using 'soapy' water or similar solution.

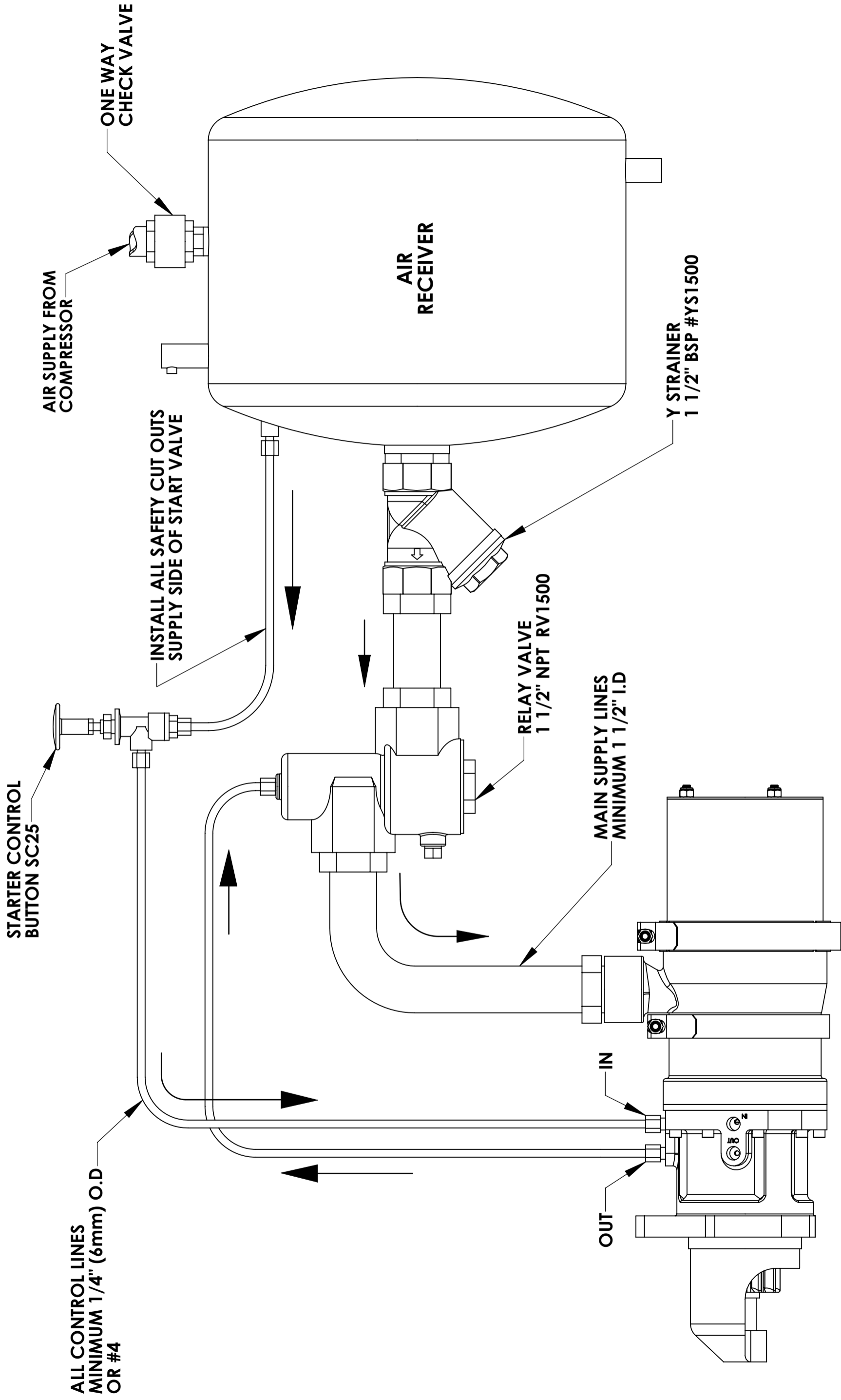

TITLE

ATS93-Schematic

SCALE: 1:3

DATE: 4-4-13

DO NOT SCALE DRAWING

This drawing is the property of K.H.Equipment Pty Ltd. It is furnished to you for confidential information purposes only and is not to be disclosed to anyone else or reproduced or used for manufacturing purposes without the express written permission of K.H.Equipment Pty Ltd.

AUSTART

A3

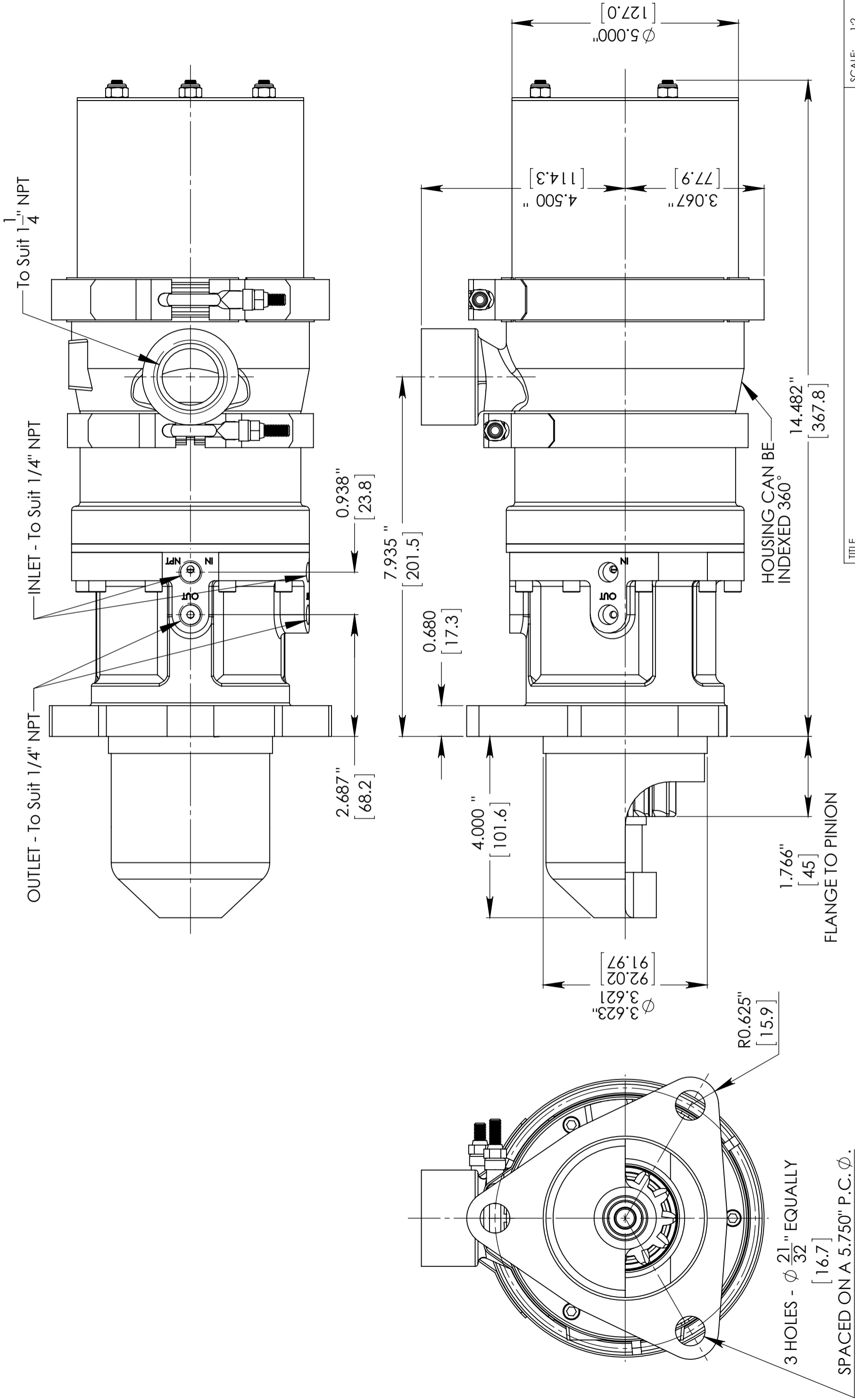

TITLE

ATS93-General Arrangement

SCALE: 1:2

DATE: 5-4-13

DO NOT SCALE DRAWING

FLANGE: SAE 3

*This drawing is the property of K.H.Equipment Pty Ltd.
 it is furnished to you for confidential information purposes
 only and is not to be disclosed to anyone else or
 reproduced or used for manufacturing purposes without
 the express written permission of K.H.Equipment Pty Ltd.

AUSTART

A3

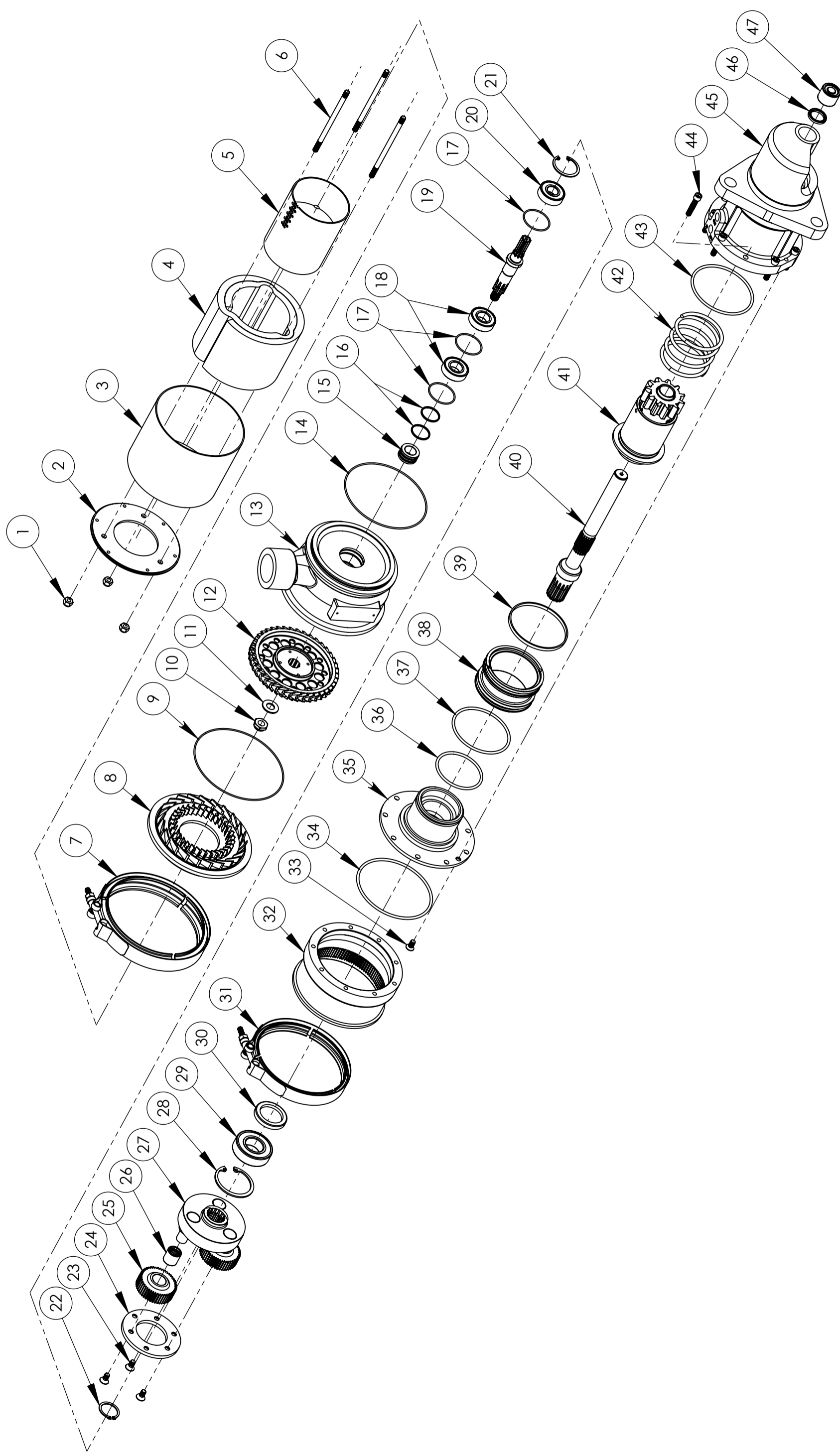

TITLE

ATS93-Exploded View

SCALE: 1:5

DATE: 4-4-13

DO NOT SCALE DRAWING

This drawing is the property of K.H.Equipment Pty Ltd. It is furnished to you for confidential information purposes only and is not to be disclosed to anyone else or reproduced or used for manufacturing purposes without the express written permission of K.H.Equipment Pty Ltd.

AUSTART

A3

PARTS BREAKDOWN

AUSTART ATS93

General Build List

ITEM	PART NO	EXT.	DESCRIPTION	QTY	ITEM	PART NO	EXT.	DESCRIPTION	QTY
1	3029	000	NUT	3	26	8315	000	BEARING	+ 1
2	9306	100	END COVER MUFFLER	1	27	8316	900	SPIDER HUB ASSY	1
3	9307	100	OUTER SLEEVE	1	28	7020	000	CIRCLIP	+ 1
4	9308	500	FOAM INSERT	1	29	7021	000	BEARING	+ 1
5	9309	900	INNER SLEEVE ASSY	1	30	7022	000	SEAL	+ 2
6	9310	100	STUD	3	31	7322	000	BAND CLAMP	1
7	9322	000	BAND CLAMP	1	32	8317	100	GEAR CASE	1
8	9321	200	END COVER	1	33	8024	000	COUNTERSUNK SCREW	1
9	9323	000	O RING	1	34	8023	000	O RING	+ 1
10	7301	000	SPECIAL NUT	1	35	8025	310	BEARING HOUSING	1
11	7304	000	WASHER	1	36	8026	000	O RING	+ 1
12	9314	320	TURBINE ROTOR	1	37	7033	000	O RING	+ 1
13	9302	940	TURBINE HOUSING NEW	1	38	8028	100	PISTON	1
14	7310	000	O RING	1	39	8029	500	SEAL	+ 1
15	7312	100	SEAL SLEEVE	1	40	8030	155	DRIVE SHAFT	1
16	7313	000	PISTON RING	2	41	8031	XXX	DRIVE ASSY	1
17	7309	000	O RING (FROM S/No 22360 USE 3)	3	42	6734	000	SPRING	1
18	6611	000	BEARING (FROM S/No 22360 USE 2)	2	43	7023	000	O RING	+ 1
19	9303	101	ROTOR SHAFT	1	44	8318	000	SCREW	9
20	7004	000	BEARING	1	45	8034	XXX	NOSE HOUSING	1
21	6612	000	CIRCLIP	1	46	8036	000	SEAL	+ 1
22	7018	000	CIRCLIP	1	47	8037	000	BEARING	+ 1
23	6305	000	COUNTERSUNK SCREW	3					
24	8306	100	RETAINER	1		9340	900	SERVICE KIT	CONSIST AS MARKED +
25	8307	100	PLANET GEAR	3					

- XXX DENOTES OPTIONS AVAILABLE

ATS93/3 (A) REV.04 01/03/2013

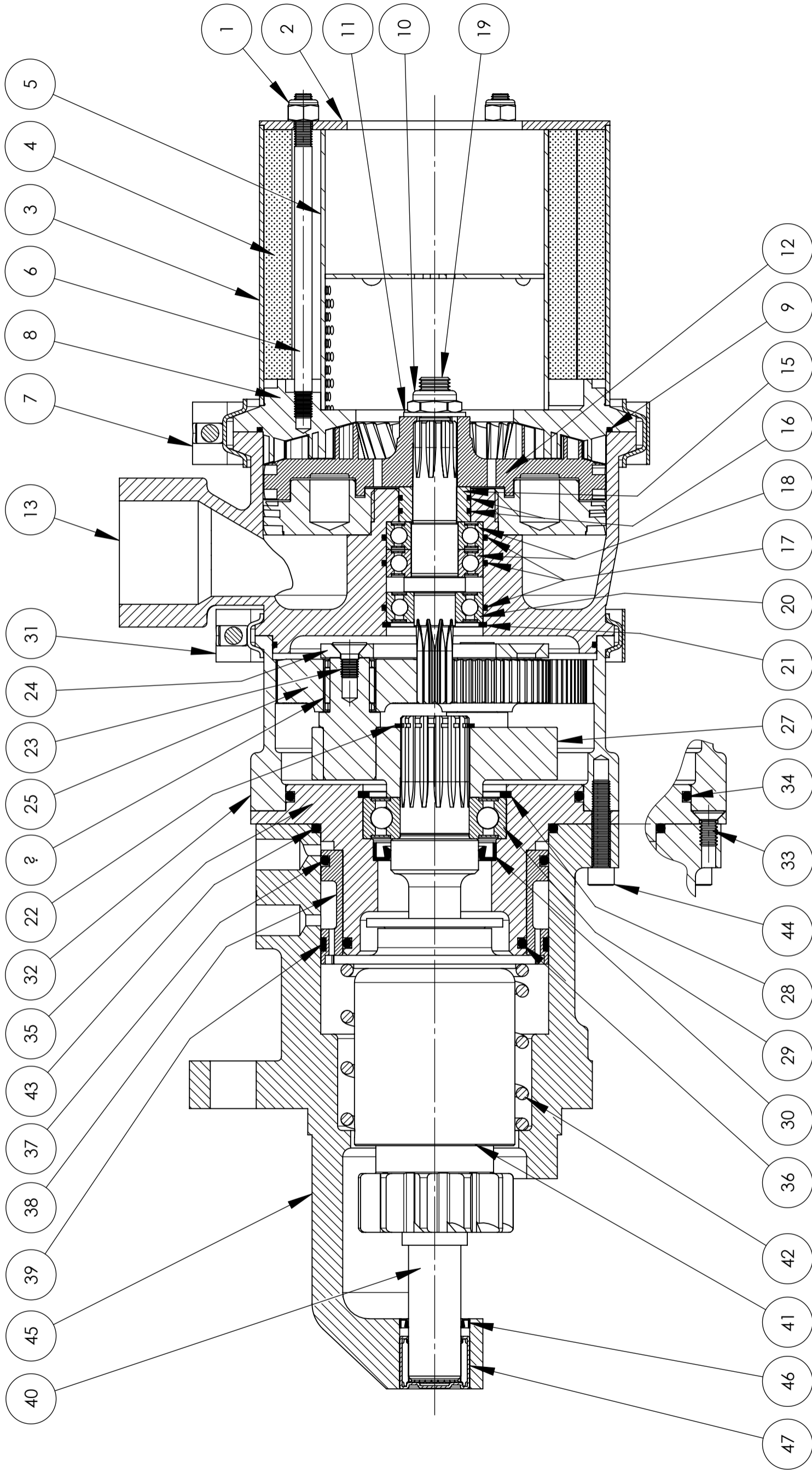

TITLE

ATS93-Section View

SCALE: 1:1.5
 DATE: 4-4-13
 DO NOT SCALE
 DRAWING

This drawing is the property of K.H.Equipment Pty Ltd. It is furnished to you for confidential information purposes only and is not to be disclosed to anyone else or reproduced or used for manufacturing purposes without the express written permission of K.H.Equipment Pty Ltd.

AUSTART A3

MAINTENANCE



DISASSEMBLY

Refer to the Exploded View and Cross Sectional View drawings on pages 8 & 10.

Begin by removing the two band clamps (7) and (31) and separate the three sub-assemblies; the nose assembly, the motor assembly and the silencer assembly. Gently tap the assemblies with a soft hammer if necessary.

The sub-assemblies may now be dismantled separately. Disassembly of any of these three sub-assemblies is detailed in the exploded view on page 8 and is basically in the order shown. Refer also to the following instructions:

NOSE ASSEMBLY

1. Remove retainer (24), planet gears (25) and bearings (26). If necessary gently tap the three countersunk screws (23) to loosen them.
2. Remove nine screws (44) and separate the gear case (32), bearing housing (35) and nose housing (45). Gently tap with a soft hammer to assist separation if necessary.
3. Remove the two countersunk screws (33). The bearing housing (35) should spring apart from the nose assembly. Gently tap the nose housing (45) with a soft hammer to assist it to separate if necessary.
4. Remove spring (42), drive assembly (41) and piston (38).
5. Support bearing housing (35) in the vertical position and gently press out drive shaft (40) from bearing (29).
6. Remove circlip (28) using circlip pliers and press out bearing (29) and seal (30).
7. Remove nose bearing (47) and seal (46) from nose housing (45).

MOTOR ASSEMBLY

1. Remove special nut (10) and washer (11). Difficulty may be experienced and it will be necessary to restrain the turbine rotor (12) from turning by using a ring spanner (wrench) on the special flats provided.
2. Remove circlip (21) using circlip pliers and press out rotor shaft (19) through rotor (12) as an assembly.
3. Press out seal sleeve (15) and bearing/s (18) (two bearings fitted from serial number 22360 onwards) from turbine housing (13).
4. Press off Bearing (20) from the rotor shaft (19).

SILENCER ASSEMBLY

Remove the three nuts (1) and assembly will easily come apart.

INSPECTION

Refer to the Exploded View and Cross Sectional View drawings on pages 8 & 10.

1. Visually inspect all parts removed during disassembly for excessive wear or damage. Replace any damaged or questionable parts.
2. Pay particular attention to the vanes on end cover (8) and turbine rotor (12) and look for cracks, chipping, warping or excessive wear patterns. Rotor (12) should fit tightly on to the rotor shaft (19). Replace any damaged or questionable parts and remove burrs.
3. Also pay particular attention to all gear teeth looking for cracked or broken teeth and excessive wear. Check the pinion on the drive assembly (41) for evidence of unusual contact patterns resulting from misalignment or improper engagement. Remove any burrs or replace if questionable.
4. Check all bearings are free to rotate and do not have excessive play between races. If in doubt replace questionable bearings.

CAUTION

Do not wash shielded bearings that are to be reused in solvent or blow with compressed air as it may remove internal lubrication. Bearings that are to be reused should be cleaned by wiping the end shields with a clean cloth.

5. Clean all other parts that are going to be reused with commercially approved solvents.

WARNING

Ensure cleaning operations are carried out in a properly vented area away from open flames.

6. It is recommended that when servicing your AUSTART Turbine Starter always replace complete repair kit contents.

REASSEMBLY

Refer to the Exploded View and Cross Sectional View drawings on pages 8 & 10.

Reassembly of any of the three sub-assemblies detailed in the exploded view on page 8 is basically in the reverse order shown. Refer also to the following instructions:

NOSE ASSEMBLY

1. Begin by pressing the bearing (47) and seals (46) into the nose housing (45) using a press with an appropriate pressing tool.
2. Drive home the seal (30) into the bearing housing (35) until it bottoms.

CAUTION

Ensure the seal (30) is fitted the correct way ie. with the tapered leading edge engaged first. Liberally grease the exposed side of the seal (30) with lithium based grease such as Valvoline Valplex EP grease or similar.

3. Using a press drive home the bearing (29) into the bearing housing (35) until it bottoms. Then insert shaft (40) into the bearing (29) and press home. Ensure the bearing housing (35) is adequately supported during this operation. Finally fit circlip (28) using circlip pliers.
4. Slip on spider hub assembly (27) onto shaft (40) and fit circlip (22) using circlip pliers.
5. Fit o'rings (34), (36) and (43) onto bearing housing (35).
6. Fit o'ring (37) and wiper seal (39) onto piston (38).
7. Liberally grease piston (38), the inner portion of the bearing housing (35) and shaft (40) where it extends. Then gently slide piston (38) onto the bearing housing without damaging o'ring (36).

8. Slide drive assembly (41) onto shaft (40) and then fit spring (42) over drive assembly (41).
9. Liberally coat the inner regions of nose assembly (45) and bearing (47) with grease and assemble nose assembly over piston (38) taking care not to damage wiper seal (39). Rotate the nose assembly until the two countersunk screw holes line up between the nine main screw holes.
10. Squeeze together gearing housing (35) and nose assembly (45) being careful not to damage o'ring (43), then insert countersunk screws (33).
11. Slide gear case (32) onto bearing housing (35) ensuring o'ring (34) is not damaged by smearing oil on the o'ring (34) to allow gear case (32) to easily slide over.
12. Line up set screw holes and install nine setscrews (44).
13. Invert the built up nose assembly and restrain in the vertical position. Install the three planet gears (25) and gear bearings (26) onto the spider hub assembly (27).
14. Coat gear bearings with grease before assembly.

CAUTION

Ensure planet gears (25) are installed with the boss side of the gear facing the spider hub assembly (27).

15. Install retainer (24) to the spider hub assembly (27) and install the three countersunk screws (23).
16. Liberally pack gear teeth with suitable grease such as Valvoline Valplex EP or similar.

The nose assembly is now ready to accept the motor assembly.

MOTOR ASSEMBLY

1. Begin by lightly oiling the internal bore of the turbine housing (13) with hydraulic oil and fitting inner o'ring/s (17) (two o'rings fitted from serial number 22360 onwards).
2. Evenly press home bearing/s (18) (two bearings fitted from serial number 22360 onwards) until they bottom. Ensure o'ring/s (17) are not damaged or dislodged.
3. Install piston rings (16) onto seal sleeve (15). Rotate piston rings (16) so that the gaps are 180° apart.
4. Lightly grease the outside of the piston rings (16) on the seal sleeve (15) and push home into the turbine housing (13) until it bottoms.
5. Press bearing (20) onto rotor shaft (19) using a press and liberally grease top of bearing.
6. Install third o'ring (17) into turbine housing (13) and insert rotor shaft (19) and bearing (20) as an assembly. This should be achieved with an even push fit.
7. Insert circlip (21) with circlip pliers.
8. Fit turbine rotor (12) onto rotor shaft (19) extension.
9. Lightly oil thread on rotor shaft (19) extension and install washer (11) and special nut (10). Tighten nut against the turbine rotor (12) to a torque of 25-30 ft lb. (30-40Nm.) Prevent the turbine rotor (12) from turning by using a ring spanner (wrench) on the special flats provided.

ASSEMBLING NOSE & MOTOR ASSEMBLIES

1. Apply grease to planet gears (25) and gear case (32). Carefully line up spline of motor assembly shaft (19) with the planet gears (25) on the nose assembly and slide the nose assembly home.
2. Line up the nose assembly and motor assembly air inlet ports and install band clamp (31). Tighten band clamp (31) to 4ft lb (6 Nm).
3. Test the operation of the drive assembly (41) by introducing air pressure at the control line inlet port. The drive assembly should move freely forward when air pressure is applied and back once the pressure has been relieved. Investigate if this movement is not smooth.
4. The nose/motor assembly is now ready to accept the silencer assembly.

ADDING SILENCER ASSEMBLY

1. Install silencer assembly to the turbine housing (13). Install band clamp (7). Tighten band clamp (7) to 4 ft lb (6 Nm).
2. The AUSTART Air Starter is now assembled and ready for installation. Refer to Installation and Operation section for this manual.

WARRANTY POLICY

All Austart Products supplied by K.H. Equipment Pty. Ltd. (herein called "the Manufacturer") is warranted to be free from any defect in workmanship and material under conditions of normal use and service for engine starting applications for a period of 12 months from the date of purchase by the first user. Normal wear and tear is excluded from the warranty cover.

The Manufacturer will replace or repair at their works, without cost, any Austart Starter or parts found to be defective or at their discretion choose to refund the purchase price less a reasonable allowance for depreciation in exchange for the starter or part should the item prove impossible to repair or replace.

This warranty shall not apply to any Austart Starter or parts which have been altered or repaired or purchased outside the Manufacturer and its assigned agents nor to equipment or parts that have been subject to misuse including overloading, neglect, accident or damage, nor to any part or parts improperly applied or installed.

This warranty is in lieu of all other warranties and conditions statutory or otherwise expressed or implied and of all other obligations or liabilities on the Manufacturer's part. The Manufacturer's maximum liability is limited to the purchase price of the starter and is not liable for any consequential damage, loss or expense.

Repeat engine starting attempts must be delayed for 15 seconds to allow all Austart Starter and engine components to stop rotating to avoid damage or adverse wear of components.

